

This camera manual library is for reference and historical purposes, all rights reserved.

This page is copyright by mike@butkus.org M. Butkus, N.J.

This page may not be sold or distributed without the expressed permission of the producer

I have no connection with any camera company

If you find this manual useful, how about a donation of \$3 to: M. Butkus, 29 Lake Ave., High Bridge, NJ 08829-1701 and send your E-mail address too so I can thank you. Most other places would charge you \$7.50 for a electronic copy or \$18.00 for a hard to read Xerox copy. These donations allow me to continue to buy new manuals and maintain these pages. It'll make you feel better, won't it?

If you use Pay Pal, use the link below. Use the above address for a check, M.O. or cash. Use the E-mail of butkusmi@ptd.net for PayPal.



[back to my "Orphancameras" manuals /flash and light meter site](#)

Only one "donation" needed per manual, not per multiple section of a manual !

The large manuals are split only for easy download size.

Magazine Operation

Loading the Magazine (figures 1 - 8)

You can load the magazine with film when it is either on or off the camera. Off the camera you have to ensure that the magazine slide is inserted with its flat side towards the rear.

Follow the procedure below to load a film. Paragraph numbers refer to the corresponding figure.

cw=clockwise; **ccw**=counter-clockwise

1. Fold out the film holder key.
2. Turn the key **ccw** and withdraw the film holder (magazine insert).
3. Place an empty take-up spool under the grooved knob of the spool clamp bar. Insert a roll of film under the other end of the bar, turned as in the picture. Remove all of the paper band surrounding the roll!
4. Turn the film holder key **cw** to open the film clamp. Pull 8-10 cm (3-4 in.) of paper backing off the film roll. Slide the side edge under the clamp.
5. Insert the tongue of the backing paper into the slot in the take-up spool.
6. Turn the grooved knob **cw** to align the arrow on the paper with the triangular index on the bar, **but no further**.
7. Turn the film holder key **ccw**. Insert the film holder into the magazine. Ensure that it is correctly positioned. Turn the film holder key **cw** to lock the film holder in the magazine.
8. Fold out the film winding crank. Rotate it **cw** about ten turns until it stops. Turn it **ccw** and fold it in.

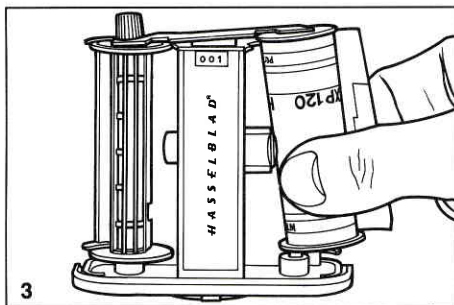
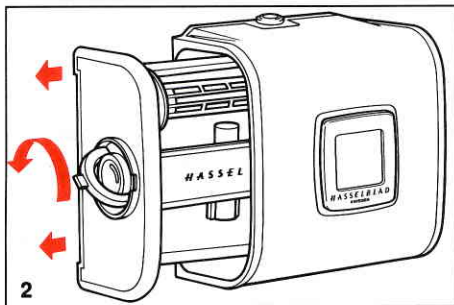
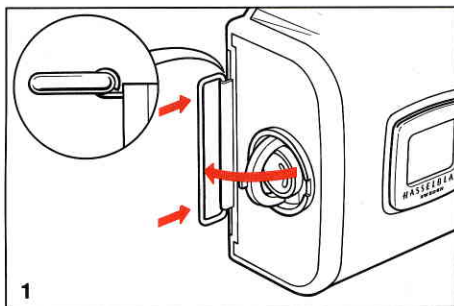

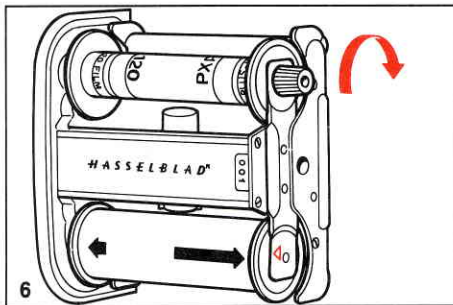
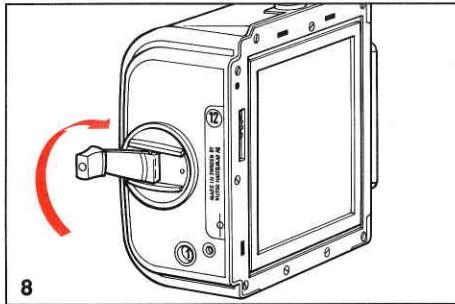
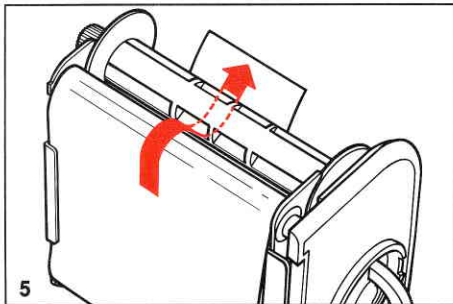
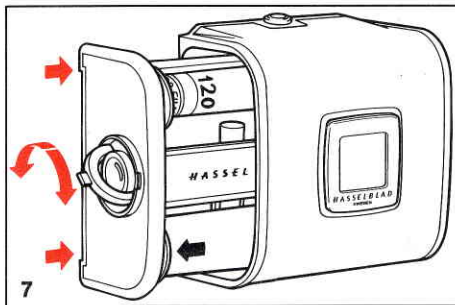
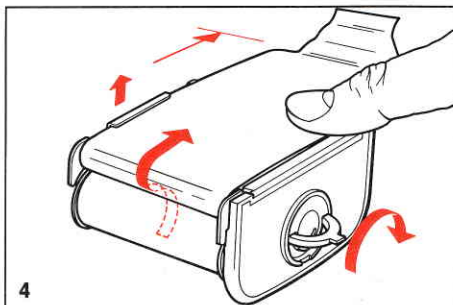

Number 1 will now be displayed in the frame counter window indicating that the loaded magazine is ready for use. The film winding crank is blocked at frame 1 only. It can be used to wind up a partially exposed film at any frame after that. The frame counter is automatically reset when the film holder is withdrawn from the magazine.

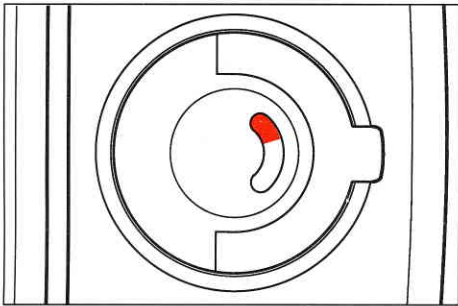

Magazine Load Status

In the center of the film holder key there is a crescent-shaped indicator window that shows white when the magazine is freshly loaded. It gradually changes to red as the film is wound through. An all red indicator shows that the film is used up or that the magazine is empty.

Removing the Film

When the film has been advanced after the last frame, the magazine blocks the camera against further exposure release. To remove the exposed film, fold out the film winding crank and rotate it clockwise until you can feel that the film is leaving the supply spool. Withdraw the film holder from the magazine and remove the film.

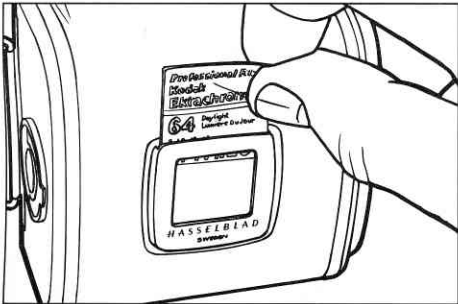

Film Tab Holder

The end tab of the film pack can be inserted in the holder on the back of the magazine as a reminder of the kind of film that has been loaded into the magazine.

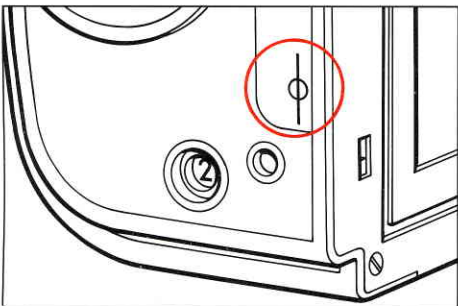

Film Plane Index

The film plane index on the right hand side of the magazine body indicates the position of the film plane. It can be used to for accurate determination of the subject-to-film distance, which is important in close-up photography.

Flash Photography

Automatic Flash Control

When a dedicated flash unit, such as the Hasselblad Proflash 4504, or any other unit complying with the European SCA-standards, is connected to the TTL flash socket (page 26,37) – directly or through a suitable adapter – the built-in sensor and flash control circuits in your 201F controls the flash duration by TTL/OTF metering (TTL=Through The Lens; OTF=Off The Film). This means that it meters the light reflected off a central portion of the film surface, and terminates the flash when the exposure is correct, according to the film speed you have selected with the film speed dial (page 26, 36). The flash control circuit and the flash adapter, when used, is powered from the flash unit and consumes no energy from the camera battery.

Any electronic flash unit including the dedicated flash types can be connected to the PC socket. Then, however, you no longer have the advantage of letting the camera system control the flash and the exposure when you are using a dedicated flash unit.

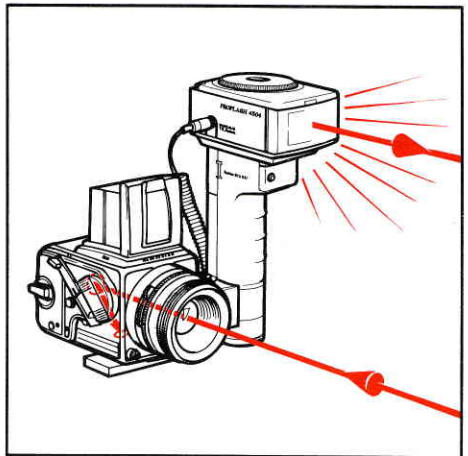
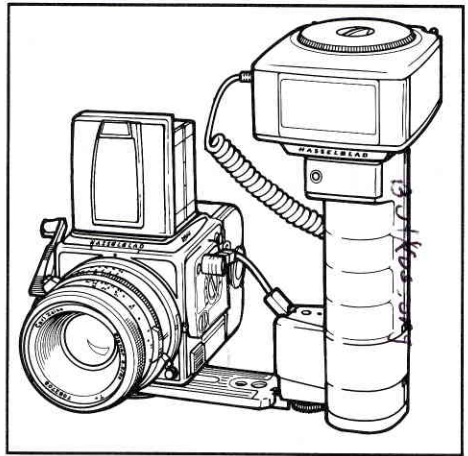

Viewfinder Signal

The flash operation signal is combined with the battery check indicator (page 18).

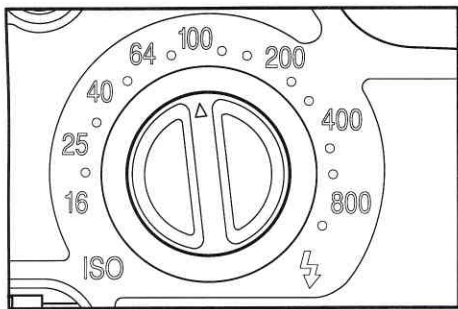
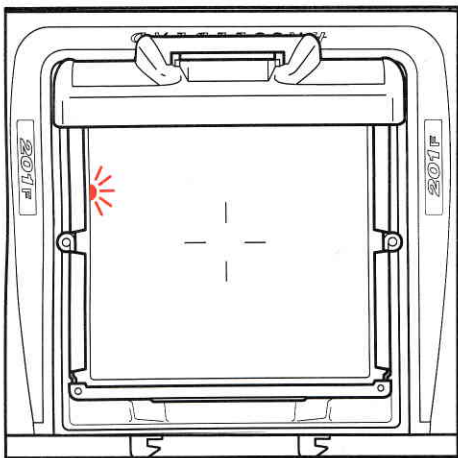

It is operative as flash signal only when a dedicated flash is connected to the TTL socket.

The signal has three different states of indication; a ready signal, an exposure confirmation signal and no signal.

Ready Signal

A fixed red light indicates that the flash unit is fully charged and ready to operate.

Confirmation Signal

A flashing red light that appears during a little longer than a second immediately after the exposure confirms that the light output was sufficient for a proper exposure. After the confirmation signal the indicator remains dark until the ready signal reappears, indicating that the flash unit is operative again.

No signal

Absence of the confirmation signal indicates that the light output from the flash unit was insufficient for a correct exposure.

Setting the Film Speed

The film speed is set with the ISO selection dial. The setting range is ISO 16 – 1000. The equivalent DIN numbers are shown in the table below. Certain films, e.g. Polaroid, need compensation for differences in reflection. Such compensation is made by changing the film speed setting. The amount of compensation has to be determined by experiment.

ISO/ASA	16	•	25	•	40	•	64	•	100	•	•	200	•	•	400	•	•	800	•
DIN	13	14	15	16	17	18	19	20	21	22	23	24	25	26	27	28	29	30	31

How to Use the Dedicated Flash Flash in TTL-mode

For the operation of the flash unit please refer to the flash unit Instruction Manual.

Camera Functions:

- Fully automatic exposure control through TTL/OTF metering.
- Exposure with preset aperture and shutter speed of 1/90 s or slower.
- Automatic disabling of flash triggering when the preset shutter speed is faster than 1/90 s.
- Viewfinder indication:
 - when the flash unit is charged and ready to flash,
 - when the exposure was correct,
 - when the exposure was insufficient.

Suggested procedure:

1. Set the film speed with the Film Speed Dial. Attach and connect the flash unit according to the flash unit Manual. With the Hasselblad Proflash 4504 connect the Hasselblad TTL-cable between the TTL socket in the camera body (page 26) and the TTL socket in the flash unit. The PC cable connector is inoperative but can be “parked” in the PC-socket.
2. Set the flash unit at TTL or corresponding mode and switch it on. When the flash unit is charged and ready to flash, the indicator in the viewfinder lights up with a fixed red light.

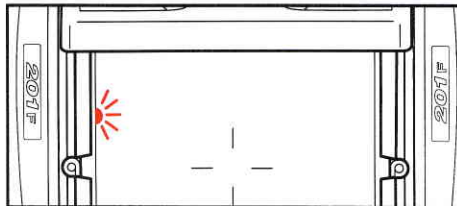
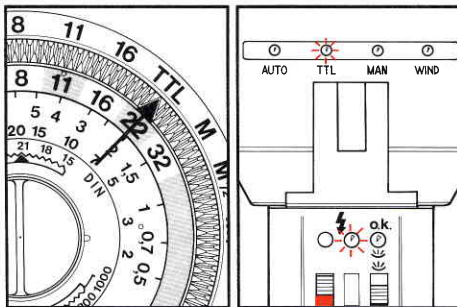
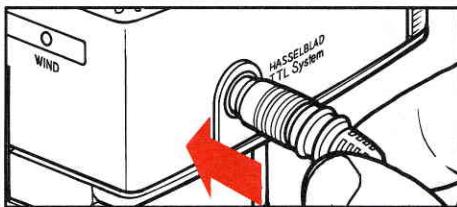
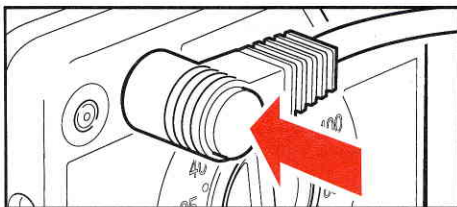

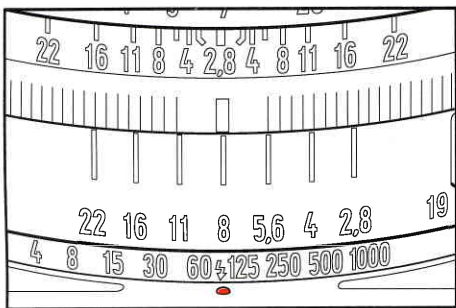

3. Select and preset the aperture for the desired depth-of-field. Preset the shutter speed at 1/90 s (or slower if required).

NOTE: The flash is not triggered at selected shutter speeds faster than 1/90 s to avoid unexpected exposure failures.

Shutter speeds slower than 1/90 s are operative and may result in unwanted mixed-light exposures when the flash and the camera are used in TTL mode.

4. Depress the exposure release button to make the exposure and trigger the flash. The control circuits in the camera cut the flash when the exposure is correct. If the flash was powerful enough to produce a correct exposure but did not use up all the power, the viewfinder signal turns to the "ready" state directly after the flashing confirmation signal. If it did use up most of the power, the signal turns off after the confirmation while the flash unit is recharging and lights up again when it is fully recharged.

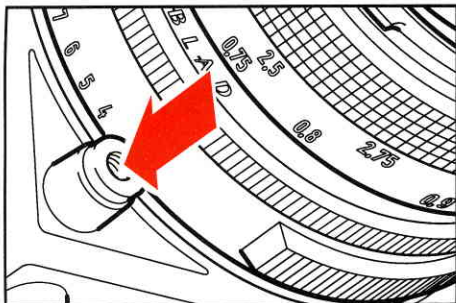

WARNING: Absence of the confirmation signal indicates underexposure. The remedy is to move closer to the subject, select a larger aperture, use a faster film or any combination of these actions.

5. Rewind the camera to cock the shutter and advance the film to the next frame.

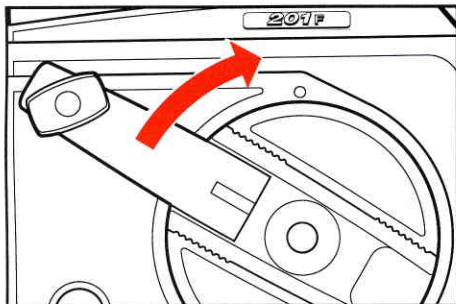

Flash in other mode than TTL

A dedicated flash unit, connected to the TTL socket and set in any other mode than TTL, will not be controlled by the camera but will still trigger the “ready” and “confirmation” indications in the viewfinder. The flash function and the viewfinder indications, however, are regardless of the film speed setting on the camera.

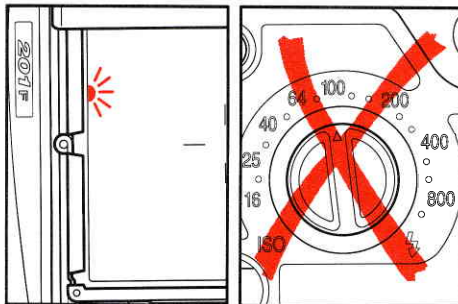
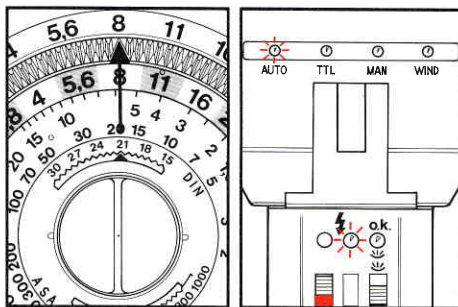

Non-dedicated Flash Units

Any kind of electrically powered flash unit connected to the PC-socket will only be triggered but not controlled by the camera. The viewfinder signals will not be operating. The PC-socket is inoperative at shutter speed settings faster than 1/90 s to avoid exposure failures.

NOTE: High power studio flash units may in some cases have a flash duration longer than 1/90 s. When using such equipment you are recommended to set the shutter speed at 1/60 s or slower to avoid uneven exposure due to shutter curtain movement.

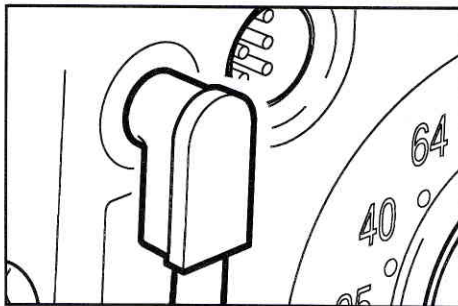



201F with other Hasselblad Lenses

You can use the Hasselblad F-, CF- and C-lenses on your 210F camera body without fear of damaging neither camera nor lens.

The F-lenses are optically, mechanically and operationally identical with the corresponding FE-lenses. The instructions for the FE-lenses are in all parts applicable on the F-lenses.

How to use the CF- and C- lenses is described in Appendix A, page 48.

Dedicated Flash Unit

The overall similarity between the FE- and F-lenses makes the flash photography procedures identical.

Dedicated Flash Unit

The TTL/OTF flash control system makes no difference between the FE- and the F-lenses as it always operates when the lens is stopped down during the exposure.

How to use the Dedicated Flash

The procedures are identical to those described for the FE-lenses in the different flash modes of operation (pages 37-39).

Non-dedicated Flash Unit

The information on and procedure described for the use of a non-dedicated flash unit together with a FE-lens (page 39) is in all parts applicable with an F-lens.

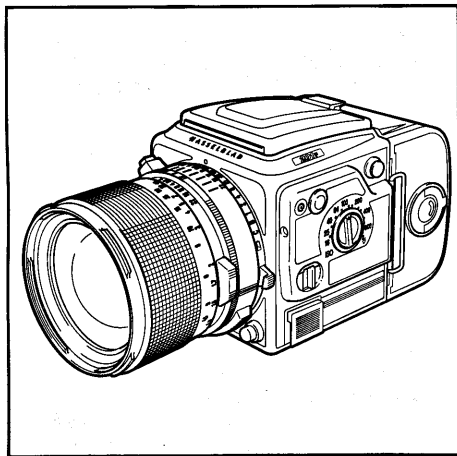

Accessories

All accessories included in the present Hasselblad Product Catalog and most discontinued older accessories can be used on the 201F when not specifically noted otherwise.

Accessory Mounts

The quick coupling plate on the bottom of the camera body (page 21) fits the handy and reliable Hasselblad tripod quick coupling and the flash gun bracket.

On the front of the lenses are external and internal bayonet mounts for filters, close-up lenses and lens shades. The viewfinder mount on top of the camera body accepts various focusing screens and viewfinders. Underneath the winding crank is a bayonet mount for the Hasselblad Winder.

Major Accessories

A couple of the most important accessories is described below. For a complete review of the Hasselblad system refer to the Hasselblad Product Catalog.

Winder

The Hasselblad Winder replaces the winding crank and motorizes the 201F for a maximum frame rate of 1,3 fps.

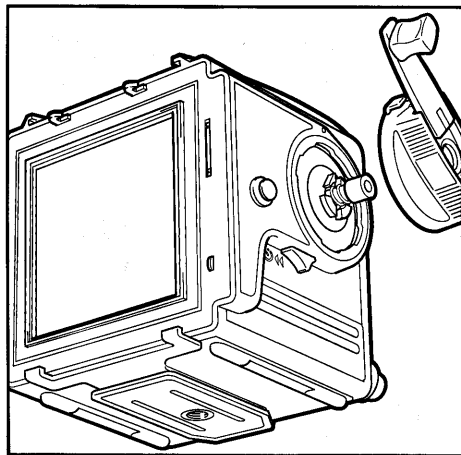

Viewfinders

Besides the focusing hood which is delivered with the camera body you have a choice of a magnifying hood and a range of prism viewfinders with and without built-in exposure meters.

The Hasselblad 201F System Chart

The accessory chart on the following pages indicates the wide range of accessories available within the Hasselblad System. Please refer to the Hasselblad Product Catalog for full information on the complete Hasselblad Camera System.

The Hasselblad 201F System Chart



CF40
FLE



CF30



CF50
FLE



FE50

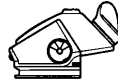

PME 51

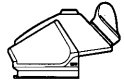

PM 5



CF60



CF105



FE80



CF80



CF120



FE110



CF100



CF135



FE150

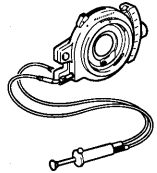

CF150

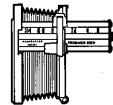

CF180



FE250



CF250



FE350



CF250



CF250Sa



CF350



CF500

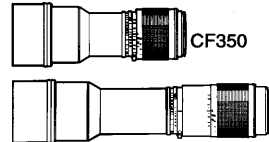

CF140-280



56 32 16 8



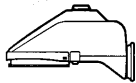

PM 90



RM-2



A12 TCC



A12



A16



A24



70

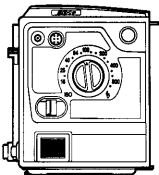
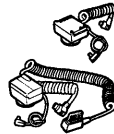
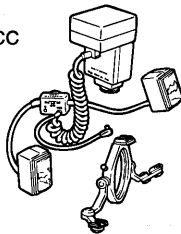

201F

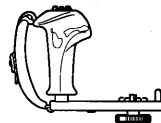
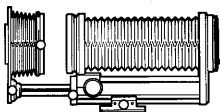
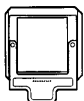
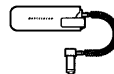
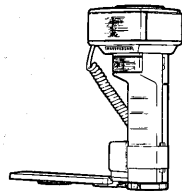

Technical Specifications and Equipment, 201F

Camera design: Medium format single lens reflex camera with built-in flash exposure control. Full image size mirror. Max. film size 6 x 6 cm (2 1/4 x 2 1/4 in) . Interchangeable lenses, film magazines, viewfinders, and focusing screens.

Shutter: Electronically controlled mechanical focal-plane shutter with release solenoid system. Horizontally running textile curtains. Shutter speed range 1s - 1/1000s and B. Fully mechanical C setting for lenses with built-in leaf shutters.
Flash synchronization at all speeds from B to 1/90s.

Lens mount: Hasselblad bayonet mount for FE, F, CF and C lenses.

Viewfinder: Focusing hood with 4.5 x magnifier, interchangeable with magnifying hood and prism viewfinders with or without exposure meter. Acute-Matte focusing screen interchangeable with other Hasselblad focusing screens. Illuminated flash indication.

Camera winding & Film advance: Manual single turn winding crank. Simultaneous shutter cocking and film advance. The crank is interchangeable with the motorized Hasselblad Winder for a frame rate of up to 1.3 fps.

Flash control: Center weighted TTL/OTF flash exposure meter powered from flash unit. Low center metering area. Full dedicated flash control with shutter speeds from B to 1/90 s. Inhibited flash triggering at shutter speeds faster than 1/90 s.

Film speed range: ISO 16/13° – 1000/31° for dedicated flash control. Selected with film speed dial on camera body.

Selftimer: Default delay 10s, optional delay 2s selected with selftimer button. Flashing selftimer indication light.

Battery: 6V, type PX28, UCAR 537, 4G-13 or equivalent Lithium type.

Tripod mount: Quick coupling plate and 1/4" and 3/8" socket thread.

External dimensions: Camera body only: See page 46.
With focusing hood, Planar FE 2.8/80mm lens with front cover, and film magazin A12: 188L x 117W x 108H mm (7 1/2 x 4 5/8 x 4 1/4 in).

Weight: 1650 g with focusing hood, Planar FE 2.8/80, A12 film magazine and battery. Camera body alone: 750 g.

The camera body (Cat. Nos.: chrome finish 10529, black finish 10532) comes with focusing hood, focusing screen, winding crank, shoulder strap, front and rear protective covers.

For comprehensive information please refer to the Hasselblad Product Catalog.

Hasselblad reserves the right to change te specifications without prior notice.

Troubleshooting

Your Hasselblad 201F is built for long and troublefree service, especially when you follow the advices on maintenance and care on page 49. Should you encounter any operational difficulties the troubleshooting chart below may help you to resolve them.

PROBLEM	POSSIBLE CAUSE	REMEDY
When the exposure release button is depressed only the mirror lifts and there is no battery check indication in the viewfinder	The battery is missing The battery is exhausted	Insert a fresh battery as described on page 6, depress the double exposure button and rewind the camera
The exposure release button cannot be depressed	The magazine slide is still in the magazine The film is finished The camera is not rewound	Remove the magazine slide completely Load a new film or change to a new loaded magazine Rewind the camera with one full turn of the winding crank
There is no image on the focusing screen	The camera is pre-released The lens front cover is on The camera has a C-lens or a CF-lens in C position on and is released	Complete the camera release or depress the double exposure button, and rewind the camera Remove the cover Rewind the camera with one full turn of the winding crank

PROBLEM	POSSIBLE CAUSE	REMEDY
The lens cannot be attached	<p>The lens is released</p> <p>The camera body is released or pre-released</p>	<p>Cock the lens</p> <p>Complete the camera release or depress the double exposure button, and rewind the camera</p>
The lens cannot be detached	The camera body is released or pre-released	Complete the camera release or depress the double exposure button, and rewind the camera
The magazine cannot be detached	The magazine slide is not completely inserted	Push the magazine slide in until it positively stops
The shutter speed ring cannot be moved	The shutter speed ring lock is engaged	Disengage the shutter speed ring lock
The flash is not triggered when the camera is released	The selected shutter speed is faster than 1/90 s.	Select a shutter speed of 1/90 s or slower
The flash "ready" signal does not light up when a dedicated flash unit is connected	<p>The flash unit is not switched on or is not fully charged to be operative</p> <p>The connection between flash unit and camera is defective</p>	<p>Switch on the flash unit and/or wait until it is fully charged</p> <p>Check the connections according to the flash unit's manual</p> <p>Replace the TTL sync cord</p>
The "confirmation" signal does not appear after a dedicated flash exposure	The flash unit's batteries are too exhausted to recharge the unit.	Replace the flash unit's batteries with fresh ones

Camera Body Dimensions

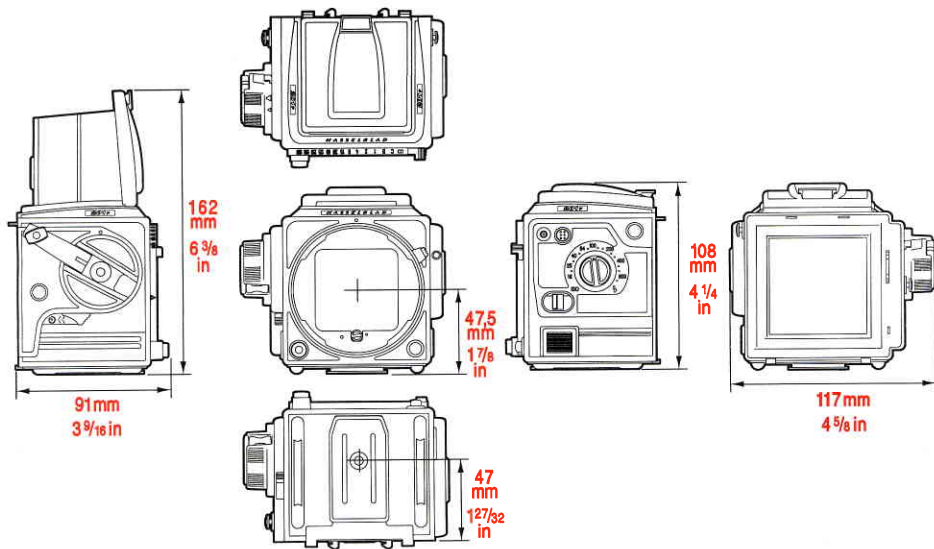

Camera Care, Service and Guarantee

Camera Care.

Your Hasselblad camera is designed to withstand the rigours of professional use in most environments. In order to avoid the possibility of damage, however, the camera should be protected from the following.

Extremes of temperature. High temperatures can have an adverse effect on both the film and the camera. Do not keep your camera in places where it may get hot, such as in direct sunlight or above a radiator. In tropical environments fungus growth can be prevented by keeping your equipment in an area where the air is circulating. Frequent rapid and severe temperature changes can cause problems such as corrosion of electrical contacts, and should be avoided. When in extremely cold temperatures, cameras and especially lenses should be protected as much as possible.

Dust and grit. Prevent dirt of any kind from getting into your camera. When taking photographs in coastal areas for example, the camera should be protected from sand and salt water spray.

You can blow away dust on the lens glass, magnifier of focusing screen, or wipe it off gently with a soft cloth if necessary. Smears on the lens glass should be removed with a high quality lens cleaning solution on a soft, clean tissue. Be careful not to scratch the lens or touch any of the glass surfaces with

your fingers. The surface of the mirror is coated and should be blown clean but not be wiped. Lens cleaning solvents or other chemicals should not be used on the focusing screen.

Impact. Your camera can be damaged by severe physical shocks. You should take care not to leave it where it can fall or be knocked to the ground, or roll about.

Service. Faultless camera performance is essential to the professional photographer. Therefore it is advisable to check that your camera is functioning correctly before an important assignment. You should also return your camera to a "Hasselblad Authorized Service Center" for periodical checking and preventive maintenance. If your camera is used constantly and intensively, exposing hundreds of rolls of film per week, checkups every six months are recommended.

Hasselblad Service Centers have the expert staff and specialized equipment necessary to ensure that your camera remains in perfect working order.

Guarantee. Provided that you bought your camera from an authorised Hasselblad outlet, it is covered by an international guarantee for one year. The guarantee document and a registration card are supplied with the camera. Keep the guarantee document carefully, but fill in the registration card and return it to your Hasselblad distributor.

APPENDIX A

Hasselblad 201F with CF- and C-lenses

The CF- and the older C-lenses differ from the FE- and F-lenses through their built-in leaf shutter with shutter speeds from 1s to 1/500s and B. Both types have full flash synchronization on all shutter speeds. The CF-lenses also have an additional shutter setting F to let the lens be used together with the focal plane shutter and the instant return mirror.

NOTE: Avoid using the 201F with a C-lens in temperature conditions below 0°C (32°F)

CF-lenses

With a CF-lens on your 201F you can choose to use the focal plane shutter with all its advantages or to disengage the focal plane shutter and benefit from the advantages of lens' built-in leaf shutter with full flash synchronization on all shutter speeds.

NOTE: When you need shutter speeds of 1/250s or faster while using a CF-lens, you are under certain conditions recommended to set the lens shutter at **F** (see page 51) and use the camera's focal plane shutter.

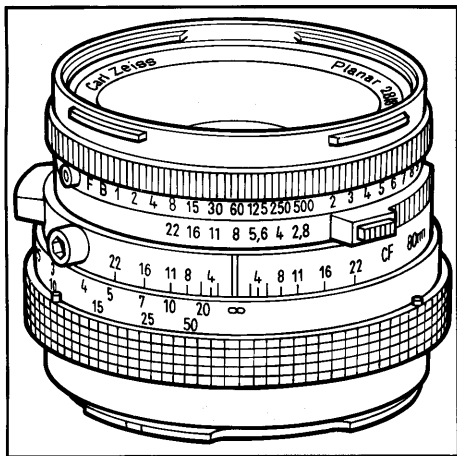

CF-lens design and functions

The setting rings and scales on the CF-lenses are arranged differently from those on the FE-lenses. Counted from the camera body and forwards the rings are:

- Focusing ring with focusing distance scale in meters (white) and feet (orange).
- Common index line and depth-of-field scale.
- Aperture ring with aperture scale and EV index (orange).
- Shutter speed ring with shutter speed scale, EV scale (orange) and F lock button (green).

EV Interlock Button

Depressing the EV interlock button interlocks the shutter speed and aperture rings to make it possible to change the shutter speed/aperture setting while retaining the EV value.

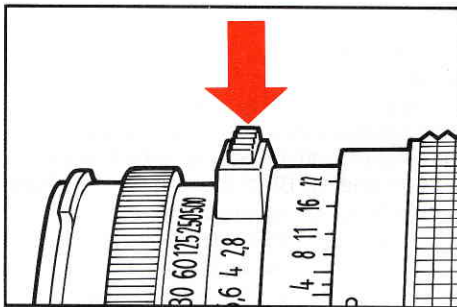

Depth-of-field Preview Knob

The Depth-of-field preview knob location and operation is identical to the FE- and F-lenses (page 29).

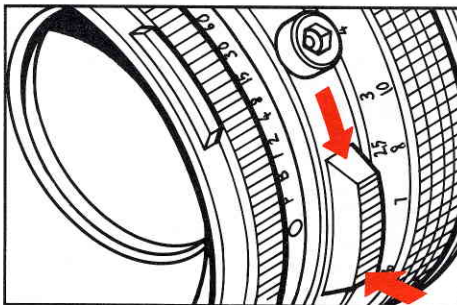

F-setting

Depress the small green F-lock button located to the left of the green F on the shutter speed ring. Keep it depressed while turning the ring to align the F with the index line. Release the button to lock the ring in the F position.

The F setting locks the shutter wide open without interfering with the aperture function. With this setting the lens works exactly as an FE- or F-lens (page 28).

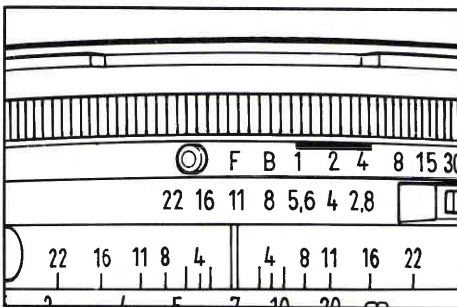

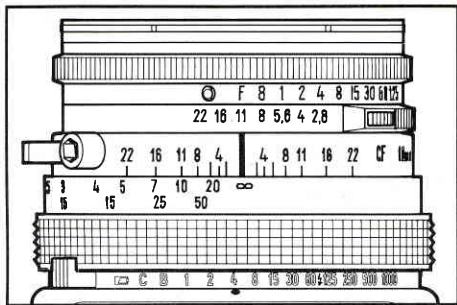

How to use the CF-lens

A. Lens in F mode (leaf shutter open)

Suggested procedure:

1. Turn the shutter speed ring to the F setting.
2. Operate the camera as described for the FE-lens (page 28).

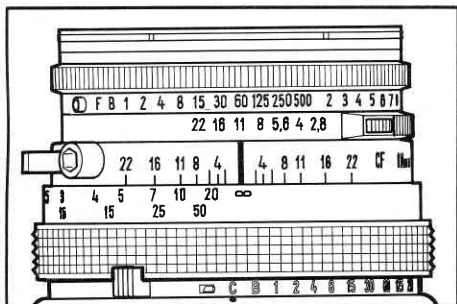

B. Lens in C mode (leaf shutter working)

When using the built-in leaf shutter in the CF-lens the focal plane shutter in the camera body must be disengaged. By setting the camera's shutter speed ring in the C position (page 18) the focal plane shutter is turned into an auxiliary shutter, used only to protect the film from inadvertent exposure.

NOTE: The leaf shutter remains closed leaving the viewfinder screen dark until the camera is rewound.

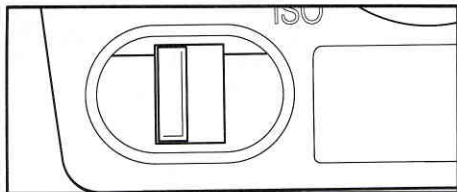
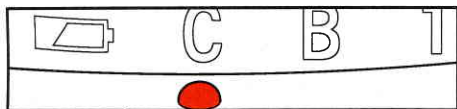

Suggested procedure:

1. Check that the lens' shutter speed ring is not set at F.
2. Turn the camera's shutter speed ring to align the C at the end of the scale with the red index mark.
3. Lock it there by engaging the shutter speed ring lock (page 26).
4. Preset the desired aperture and shutter speed on the lens scales.

5. Press the exposure button to make an exposure with the preset values.

NOTE: In temperature conditions below 0°C (32°F) the leaf shutter may react slower than normal. Be sure to keep the release button depressed until the leaf shutter has completed the exposure function!

6. Rewind the camera to get the viewfinder image back, advance the film to the next frame and to cock the lens shutter.

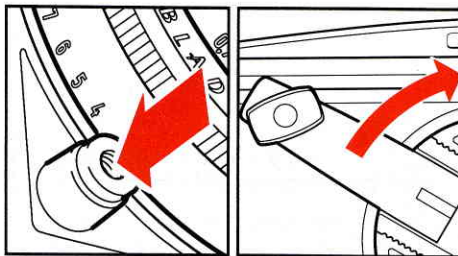

Flash photography with CF-lens

The CF-lenses have a built-in X-type flash synchronization at all shutter speeds. Flash connection is the PC socket located on **the left hand side of the lens**, close to the depth-of-field scale.

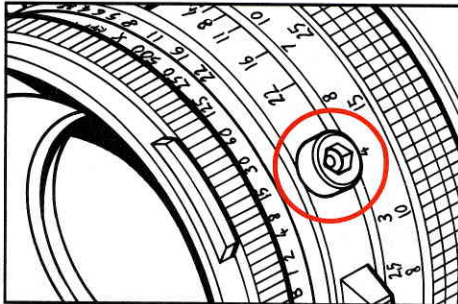

Lens in F mode

Dedicated and non-dedicated Flash Units

The procedures are identical to the corresponding procedures for the FE-lens (page 37).

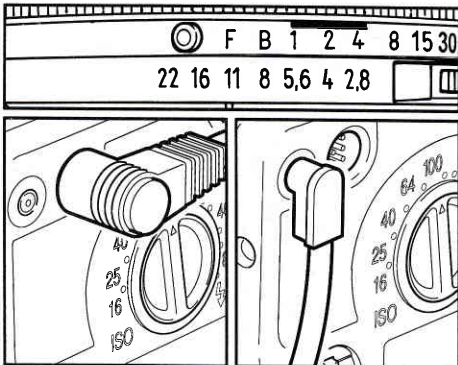

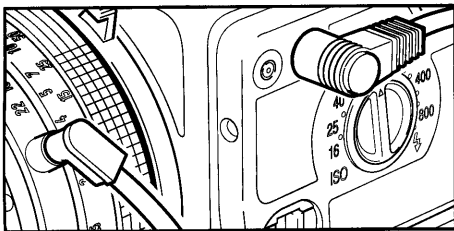
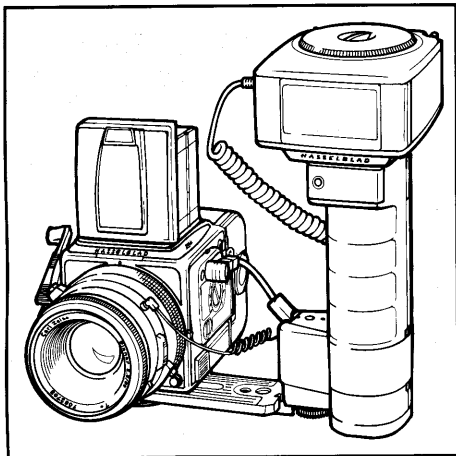

NOTE: When used at full power some electronic flash units have a flash duration longer than 1/500 s. To take advantage of the full flash power in such cases and to avoid underexposure you are recommended to use shutter speeds of 1/125 s or slower.

Lens in C mode Dedicated Flash Unit

The TTL/OTF system is working also in C-mode to control the dedicated flash unit directly – as with the Hasselblad Proflash 4504 – or through an suitable adapter. However, since the focal plane shutter is not working as a shutter, the triggering of the flash must come from the shutter in the CF-lens. The red “ready” signal and flashing “confirmation” indication appear in the viewfinder as described on page 36.

How to use the Dedicated Flash

(Camera shutter speed set at C)

Suggested procedure:

1. Attach the flash to the camera (if desired).
2. Connect the TTL-cord according to the flash instruction.
3. Connect the PC-connector to the PC-socket on the CF-lens, **not to the PC-socket in the camera body.**
4. Set the flash unit in the desired mode of operation and switch it on. The red “ready” signal in the viewfinder lights up when the flash is ready to be fired.
5. Select shutter speed and preset aperture on the lens.
6. Press and release the exposure button to make an exposure, observing the viewfinder display for the “confirmation” indication.
7. Rewind the camera to get the viewfinder image back, cock the shutter and advance the film to the next frame.

Non-dedicated Flash Units

The non-dedicated flash unit should be connected to the PC-socket on the lens only. The exposure is controlled either by the flash itself or by aperture value settings calculated from the guide number of the flash (see the flash manual). There will be no indications in the viewfinder.

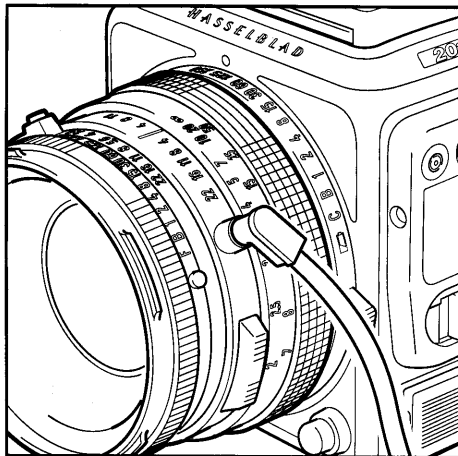

How to use the Non-dedicated Flash Unit.

(Camera shutter speed set at C).

Suggested procedure:

1. Attach the flash to the camera (if desired).
2. Connect the sync cord to the PC-socket on the CF-lens, **not to the PC-socket in the camera body.**
3. Set the flash unit at the desired mode and switch it on.
4. Select and preset aperture and shutter speed (preferably 1/125 s or slower).
5. Press the exposure button to make an exposure.
6. Rewind the camera to get the viewfinder image back, cock the shutter and advance the film to the next frame.

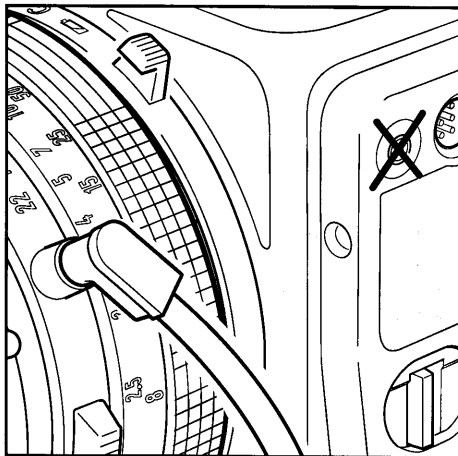

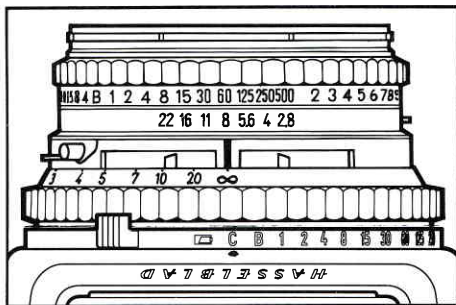
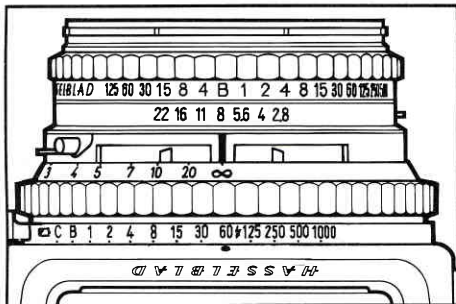
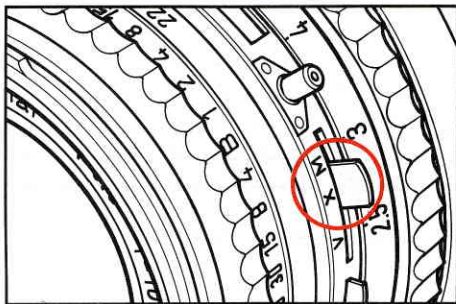

C-lenses

The older C-lenses (production terminated in 1982) look different but are in most respects identical to the CF-lenses. There are, however, certain major differences:

1. There is no F-setting on the shutter.
2. The shutter speed and aperture rings are normally interlocked.
3. There are two different flash synchronization modes.
4. There is a built-in mechanical selftimer.

How to use the C-lens

Avoid using the focal plane shutter together with a C-lens. If it cannot be avoided follow the procedure below:

1. Set the lens shutter at B.
2. Preset the desired aperture.
3. Set the camera shutter at the desired shutter speed.
4. Press the exposure button to make an exposure and **keep it depressed until the focal plane shutter has closed**. This is very important at slow shutter speeds.
5. Rewind the camera to get the viewfinder image back, cock the shutter and advance the film to the next frame.

Camera in C mode

The lens is permanently working in C-mode. The procedure is identical with the CF-lens in C-mode procedure (page 54).

Flash photography with the C-lens

Using the camera's focal plane shutter

With the lens shutter set at B the lens can be used as an F-lens.

Dedicated and Non-dedicated Flash Units

Follow the procedures for the F-lens (page 40).

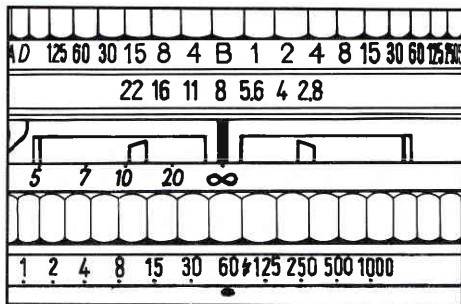

Using the C-lens' leaf shutter

Make sure that the flash mode selector is set at X.

Dedicated and Non-dedicated Flash Units

Follow the corresponding procedures for the CF-lens (page 53).

